

ATAG

SERVING INDUSTRY SINCE 1947

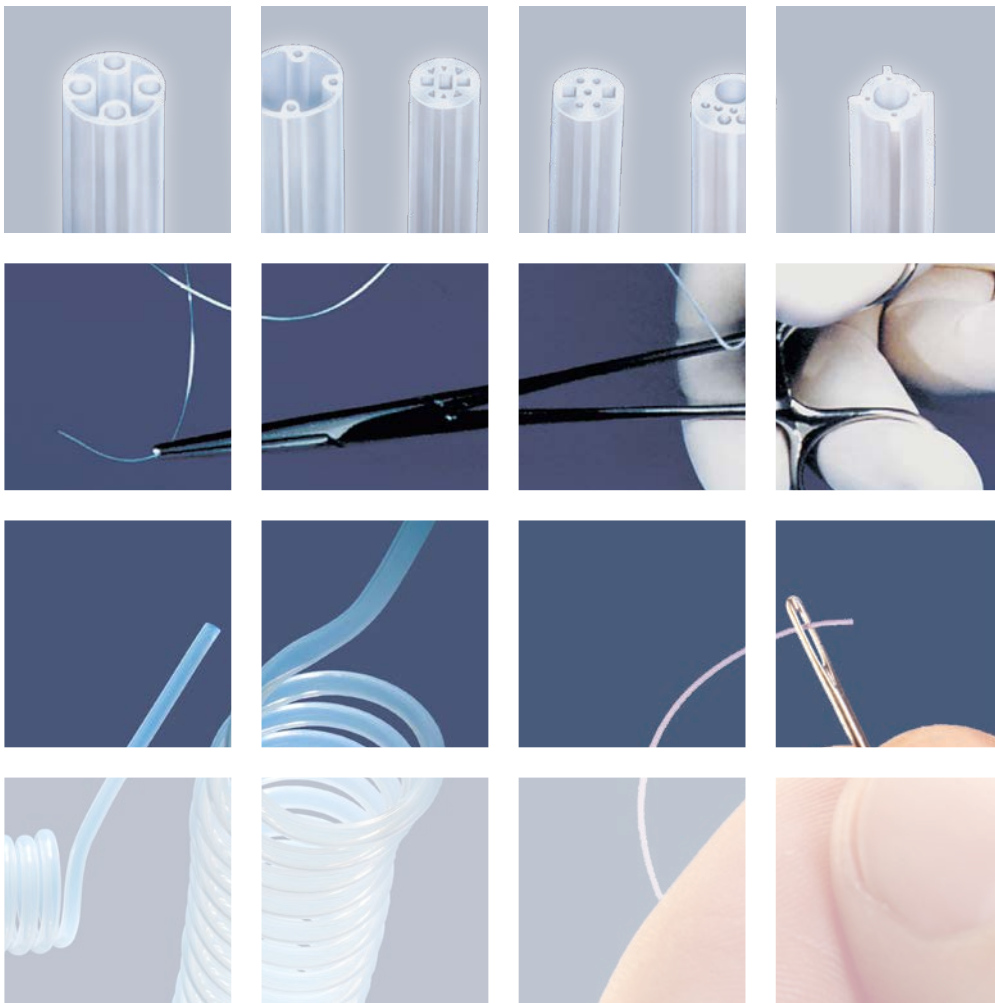

HIGH-TECH MICRO-BORE TUBING AND SLEEVING

For military, aerospace,
surgical, optical, electrical,
rail, automotive and
printing applications

PAST, PRESENT, FUTURE



ATAG is serving industry since **1947** and is constantly growing.

The wide range of products, the three domestic locations, the controlled companies, the large warehouses, the extensive sales network, the increasingly stringent internal workings, the website in constant evolution and a service based on the qualified technical expertise offered by our sales department, are the reasons why our customers rely constantly on ATAG.

In recent years we have incorporated complementary companies, using their great competencies to improve our own skills. An efficient export department, our European resellers and long-standing customers, allow us to have a better knowledge of foreign markets and strengthen our presence beyond the Italian borders.

Collaborations and agreements with international prestige partners enable us to offer our country products and solutions that are already appreciated and well established in Europe, and to stimulate our research into improved solutions for the Italian industry.

HIGH-TECH MICRO-BORE TUBING AND SLEEVING

Medical Applications

ATAG is a partner with one of the leading suppliers of fluoropolymer tubing in the medical device market who have over 40+ years of extrusion experience.

ATAG offers a wide range of fluoropolymer and specialized plastic materials for numerous medical device applications and is able to give R&D engineers turnaround, technical support and samples for prototyping.

Many of our extruded, heat shrink, and multi-lumen medical tubes have pure, smooth, non-toxic and non-allergenic properties, as well as being compatible with human tissues and fluids. Most of these are manufactured under extremely tight tolerances and their polymer properties can be customised when required.

Industrial Applications

ATAG has a strong working knowledge in many industrial sectors, including: automotive, chemical processing, electronic, aerospace and aviation, optic fibres, environmental and analytical.

We understand that new products and material enhancements are critical for customers to remain competitive and successful and so ATAG offers a wide variety of standard and specialised products to meet customers' needs.

Fluid Handling

Demand for fluoropolymer tubing in fluid handling is increasing as applications become more specialised. With diameters from 0.05 up to 51mm, ATAG's range of chemically resistant extrusions withstands corrosive fluids like sulphuric acid, hydrocarbon fuels and strong mineral acids.

The purest tubing with the smoothest surface finish is suitable for use in semiconductor and pharmaceutical applications whilst FEP Lined PE tubing for environmental and PEEK™ tubing for analytical applications are some of the specialised sectors supplied. FEP, PFA & MFA tubing is supplied for a wide range of applications such as laboratory plumbing, food processing, adhesive transfer systems as well as fuel, paint and hydraulic lines.

Electrical/Mechanical

ATAG supplies the widest range of fluoropolymer tubing for mechanical and electrical insulation applications - its' low friction, lightweight, high dielectric and tensile strength as well as high temperature characteristics means it can be used in applications where other plastics would fail.

The tubing meets or exceeds the critical environments in aviation programs. Some of these products include AWG and heat shrinkable tubing for insulation.

Other electrical applications include microware cable insulation featuring extrusions directly over wire, connector and terminal sleeves, optic fibres cable jacketing, hermetic motor insulation and battery pack and capacitor encapsulation.

To extend the life of many components ATAG also supplies a wide range of heat shrinkable extrusions that are an effective means of applying a tight jacket that withstands hostile environments of 260°C heat, abrasion and shock.

HIGH-TECH MICRO-BORE TUBING AND SLEEVING

PTFE Sub-Lite-Wall® Extruded & Heat Shrinkable Tubing

Metric Dimensions (mm)

EXTRUDED		HEAT SHRINK		
Inside Diameter (mm)	Wall Thickness (mm)	Expanded I.D. Min. (mm)	Recovered I.D. Max. (mm)	Recovered Wall Thickness (mm)
0.051	0.051	0.508	0.203	0.051
0.064	0.051	0.635	0.254	0.051
0.076	0.051	0.762	0.305	0.051
0.102	0.051	0.864	0.381	0.051
0.127	0.076	0.965	0.457	0.051
0.152	0.076	1.168	0.559	0.051
0.203	0.076	1.270	0.686	0.051
0.254	0.076	1.397	0.813	0.051
0.330	0.076	1.524	0.991	0.051
0.406	0.076	1.930	1.245	0.051
0.508	0.051	2.362	1.549	0.051
0.635	0.051	3.048	1.829	0.051
0.813	0.051	3.810	2.261	0.051
1.016	0.038	4.851	2.845	0.051
1.651	0.038	6.096	3.581	0.064
1.854	0.038			
2.134	0.038			
2.489	0.051			
2.794	0.051			
4.115	0.064			
5.182	0.089			
6.553	0.102			
8.255	0.127			

ATAG Tubing is available in both regular extruded micro-miniature dimensions, and in heat shrink versions. Inside diameters, outside diameters, and wall thicknesses are uniform throughout. The dimensions and tolerances shown here are only a guide.

You can write your own specifications with the assurance that ATAG can meet your requirements completely in either extruded or heat shrink version.

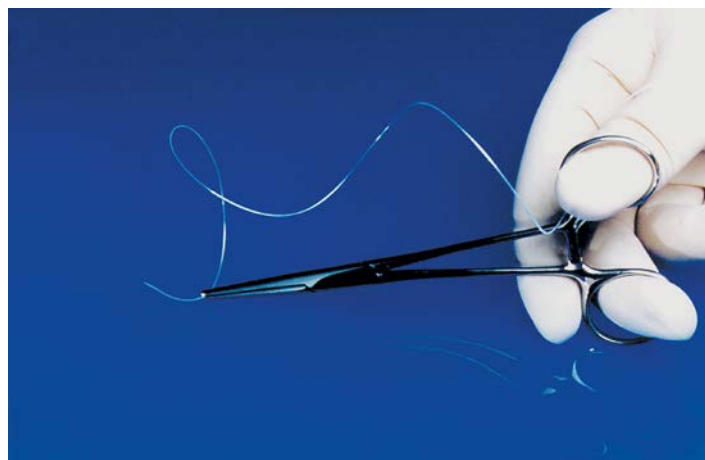

Now available in Sub-Lite-Wall® configurations with wall thicknesses down to .001 on many sizes. +/- .0005" (.013mm.) Tolerances available in most sizes.

Call us for more details.

HIGH-TECH MICRO-BORE TUBING AND SLEEVING

Extruded PTFE, FEP, PFA, ETFE Tubing

Metric Dimensions (mm)

INSIDE DIAMETER				WALL DIMENSIONS					
AWG size	Min.	Nom.	Max.	Standard Wall		Thin Wall		Lightweight Wall	
				Nom	Toll.	Nom	Toll.	Nom	Toll.
* 32	0.20	0.25	0.30	0.13	±.05	0.13	±.05	–	–
30	0.25	0.30	0.38	0.23	±.05	0.23	±.05	0.15	±.05
28	0.33	0.38	0.46	0.23	±.05	0.23	±.05	0.15	±.05
26	0.41	0.46	0.53	0.23	±.05	0.23	±.05	0.15	±.05
24	0.51	0.56	0.66	0.30	±.05	0.25	±.08	0.15	±.05
*23	0.58	0.66	0.74	0.30	±.05	0.25	±.08	0.15	±.05
22	0.64	0.71	0.81	0.30	±.05	0.25	±.08	0.15	±.05
*21	0.74	0.81	0.89	0.30	±.05	0.25	±.08	0.15	±.05
20	0.81	0.86	0.97	0.41	±.08	0.30	±.08	0.15	±.05
19	0.91	0.97	1.07	0.41	±.08	0.30	±.08	0.15	±.05
18	1.02	1.07	1.17	0.41	±.08	0.30	±.08	0.15	±.05
17	1.14	1.19	1.32	0.41	±.08	0.30	±.08	0.15	±.05
16	1.30	1.35	1.47	0.41	±.08	0.30	±.08	0.15	±.05
15	1.45	1.50	1.65	0.41	±.08	0.30	±.08	0.15	±.05
14	1.63	1.68	1.83	0.41	±.08	0.30	±.08	0.20	±.05
13	1.83	1.93	2.06	0.41	±.08	0.30	±.08	0.20	±.05
12	2.06	2.16	2.31	0.41	±.08	0.30	±.08	0.20	±.05
11	2.31	2.41	2.57	0.41	±.08	0.30	±.08	0.20	±.05
10	2.59	2.69	2.84	0.41	±.08	0.30	±.08	0.20	±.05
9	2.90	3.00	3.15	0.51	±.10	0.38	±.08	0.20	±.05
8	3.28	3.38	3.53	0.51	±.10	0.38	±.08	0.20	±.05
7	3.66	3.76	3.94	0.51	±.10	0.38	±.08	0.20	±.05
6	4.11	4.22	4.42	0.51	±.10	0.38	±.08	0.25	±.08
5	4.62	4.72	4.95	0.51	±.10	0.38	±.08	0.25	±.08
4	5.18	5.28	5.54	0.51	±.10	0.38	±.08	0.25	±.08
3	5.82	5.94	6.20	0.51	±.10	0.38	±.08	0.25	±.08
2	6.55	6.68	6.93	0.51	±.10	0.38	±.08	0.25	±.08
1	7.34	7.47	7.75	0.51	±.10	0.38	±.08	0.25	±.08
0	8.26	8.38	8.69	0.51	±.10	0.38	±.08	0.30	±.08

Material and dimensions comply with ASTM 3295, 3296; AMS 3653, 3654, 3655 and MIL-I-22129. Annual testing data provided. Lot to lot testing available upon request.

*AWG 32 not covered under ASTM or MIL standards.

On all cases of military or commercial specifications, latest revisions apply.

Supplied in natural unless otherwise specified. Custom Pantone colors or ATAG standard colors available on request.

ATAG'S TUBING complies with UL-224, has been assigned UL FILE NO. E-64007, and is listed under the UL "RECOGNIZED COMPONENT PROGRAM".

(CSA-OPT) File # 082582 has been awarded for PTFE, FEP SW and TW.

HIGH-TECH MICRO-BORE TUBING AND SLEEVING

Extruded PTFE, FEP, PFA, ETFE Tubing

Metric Dimensions (mm)

INSIDE DIAMETER				WALL DIMENSIONS					
ID inches size	Min.	Nom.	Max.	Standard Wall		Thin Wall		Lightweight Wall	
				Nom	Toll.	Nom	Toll.	Nom	Toll.
1/8"	3.05	3.18	3.30	0.51	±.10	0.38	±.08	—	—
1/8"	3.18	3.30	3.43	—	—	—	—	0.20	±.05
3/16"	4.78	4.88	5.03	0.51	±.10	0.38	±.08	0.25	±.08
1/4"	6.35	6.48	6.60	0.51	±.10	0.38	±.08	0.25	±.08
5/16"	7.95	8.15	8.43	0.51	±.10	0.38	±.08	0.30	±.08
3/8"	9.53	9.83	10.01	0.64	±.13	0.38	±.08	0.38	±.13
7/16"	11.13	11.46	11.63	0.64	±.13	0.46	±.10	0.46	±.13
1/2"	12.70	13.08	13.21	0.64	±.13	0.46	±.10	0.46	±.13
5/8"	15.88	16.33	16.51	0.64	±.13	0.51	±.10	0.51	±.13
3/4"	19.05	19.61	19.69	0.76	±.15	0.64	±.13	0.51	±.13
7/8"	22.23	22.91	23.55	0.89	±.18	—	—	—	—
1"	25.40	26.16	26.92	0.89	±.18	—	—	—	—
1" 1/4	31.75	32.69	33.66	1.02	±.18	—	—	—	—
1" 1/2	38.10	39.37	40.13	1.14	±.18	—	—	—	—

Metric Dimensions (mm)

INDUSTRIAL SPECIFICATION TUBING			
ID inches size	I.D.	O.D.	Nominal Wall Thickness
1/32"	0.79 ±0.10	1.60 ±0.10	.38
1/16"	1.60 ±0.13	3.18 ±0.13	.76
3/32"	2.39 ±0.13	3.96 ±0.13	.76
1/8"	3.18 ±0.13	4.78 ±0.13	.76
3/16"	4.78 ±0.13	6.35 ±0.13	.76
1/4"	6.35 ±0.13	7.95 ±0.13	.76
5/16"	7.95 ±0.13	9.53 ±0.13	.76
3/8"	9.53 ±0.13	11.13 ±0.13	.76
7/16"	11.13 ±0.13	12.70 ±0.15	.76
1/2"	12.70 ±0.15	14.30 ±0.15	.76
9/16"	14.30 ±0.15	15.88 ±0.15	.76
5/8"	15.88 ±0.15	17.48 ±0.15	.76
11/16"	17.48 ±0.15	19.05 ±0.15	.81
3/4"	19.05 ±0.15	21.08 ±0.15	1.02
7/8"	22.23 ±0.15	24.51 ±0.15	1.14
1"	25.40 ±0.25	27.94 ±0.25	1.27
1" 1/8	28.58 ±0.38	30.86 ±0.38	1.14
1" 1/4	31.75 ±0.38	34.04 ±0.38	1.02
1" 1/2	38.10 ±0.38	40.13 ±0.38	1.02

Metric Dimensions (mm)

INDUSTRIAL SPECIFICATION TUBING			
ID inches size	D.E.	D.I.	Nominal Wall Thickness
1/4"	6.35 ±0.13	3.18 ±0.13	1.60
5/16"	7.92 ±0.13	4.78 ±0.13	1.60
3/8"	9.52 ±0.13	6.35 ±0.13	1.60
7/16"	11.13 ±0.13	7.95 ±0.13	1.60
1/2"	12.70 ±0.15	9.52 ±0.15	1.60
9/16"	14.30 ±0.15	11.13 ±0.15	1.60
5/8"	15.88 ±0.15	12.70 ±0.15	1.60
11/16"	17.48 ±0.15	14.30 ±0.15	1.60
3/4"	19.05 ±0.15	15.88 ±0.15	1.60
13/16"	20.65 ±0.15	17.48 ±0.15	1.60
7/8"	22.23 ±0.15	19.05 ±0.15	1.60
15/16"	23.83 ±0.15	20.65 ±0.15	1.60
1"	25.40 ±0.25	22.23 ±0.25	1.60

Material and dimensions comply with ASTM 3295, 3296; AMS 3653, 3654, 3655 and MIL-I-22129. Annual testing data provided. Lot to lot testing available upon request.

*AWG 32 not covered under ASTM or MIL standards.

On all cases of military or commercial specifications, latest revisions apply.

Supplied in natural unless otherwise specified. Custom Pantone colors or ATAG standard colors available on request.

ATAG'S TUBING complies with UL-224, has been assigned UL FILE NO. E-64007, and is listed under the UL "RECOGNIZED COMPONENT PROGRAM".

(CSA-OPT) File # 082582 has been awarded for PTFE, FEP SW and TW.

HIGH-TECH MICRO-BORE TUBING AND SLEEVING

"Heavy Wall" extruded PTFE, FEP, PFA, ETFE Tubing

Metric Dimensions (mm)

INSIDE DIAMETER				WALL DIMENSIONS	
AWG	I.D. Minimum	I.D. Nominal	I.D. Maximum	Wall Nominal	Tolerance
24	.020	.022	.026	.016	± .003
23	.024	.027	.030	.016	± .003
22	.025	.0285	.032	.016	± .003
21	.030	.033	.036	.016	± .003
20	.032	.036	.040	.018	± .003
19	.036	.040	.044	.020	± .004
18	.040	.0445	.049	.020	± .004
17	.045	.0495	.054	.020	± .004
16	.051	.056	.061	.020	± .004
15	.057	.062	.067	.020	± .004
14	.064	.069	.074	.020	± .004
13	.072	.077	.082	.020	± .004
12	.081	.086	.091	.020	± .004
11	.091	.096	.101	.020	± .004
10	.102	.107	.112	.025	± .005
9	.114	.119	.124	.025	± .005
8	.129	.135	.141	.030	± .005
7	.144	.151	.158	.030	± .005
6	.162	.17	.178	.030	± .005
5	.182	.19	.198	.032	± .005

ID inches size	O.D.	I.D.	Nominal Wall Thickness
* 5/32"	0.250+/-0.005	0.156+/-0.005	0.047

* This product is specified as HW and dimensionally manufactured to ID/OD. ATAGS' Tubing complies with UL-224, has been assigned UL File Number E-64007, and is listed under the UL "Recognized Component Program".

Extruded PTFE Monofilament Tubing

Metric Dimensions (mm)

Ordered As Diameter	Tolerance
0.71	±.05
0.79	±.05
0.89	±.05
0.99	±.05
1.19	±.05
1.27	±.05
1.40	±.05
1.57	±.05
1.78	±.05
1.98	±.08
2.39	±.08
2.54	±.08
2.77	±.08
3.17	±.08
3.81	±.08

Supplied in natural unless otherwise specified. Custom Pantone colors or ATAG standard colors available on request. Material and dimensions comply with ASTM 3295. Annual testing data provided. Lot to lot testing available upon request. ASTM-D-3295 (Group 05)

HIGH-TECH MICRO-BORE TUBING AND SLEEVING

Extruded PTFE, FEP, PFA, ETFE Tubing

EXTRUDED METRIC TUBING - WALL THICKNESS 0,50 MM

Ordering Size (ID/OD)	I.D.	Tolerance ±	Wall Thickness	Ordering Size (ID/OD)	I.D.	Tolerance ±	Wall Thickness
0.50/1.50	0.50	0.05	0.50+/-0.07	5.50/6.50	5.50	0.20	0.50+/-0.07
1.00/2.00	1.00	0.05	0.50+/-0.07	6.00/7.00	6.00	0.20	0.50+/-0.07
1.50/2.50	1.50	0.10	0.50+/-0.07	6.50/7.50	6.50	0.20	0.50+/-0.07
2.00/3.00	2.00	0.10	0.50+/-0.07	7.00/8.00	7.00	0.20	0.50+/-0.07
2.50/3.50	2.50	0.15	0.50+/-0.07	7.50/8.50	7.50	0.20	0.50+/-0.07
3.00/4.00	3.00	0.15	0.50+/-0.07	8.00/9.00	8.00	0.20	0.50+/-0.07
3.50/4.50	3.50	0.15	0.50+/-0.07	8.50/9.50	8.50	0.30	0.50+/-0.07
4.00/5.00	4.00	0.15	0.50+/-0.07	9.00/10.00	9.00	0.30	0.50+/-0.07
4.50/5.50	4.50	0.20	0.50+/-0.07	12.00/13.00	12.00	0.30	0.50+/-0.07
5.00/6.00	5.00	0.20	0.50+/-0.07	13.00/14.00	13.00	0.50	0.50+/-0.07

EXTRUDED METRIC TUBING - WALL THICKNESS 1,00 MM

Ordering Size (ID/OD)	I.D.	Tolerance ±	Wall Thickness	Ordering Size (ID/OD)	I.D.	Tolerance ±	Wall Thickness
1.00/3.00	1.00	0.05	1.00+/-0.15	18.00/20.00	18.00	0.40	1.00+/-0.15
2.00/4.00	2.00	0.10	1.00+/-0.15	19.00/21.00	19.00	0.40	1.00+/-0.15
2.50/4.50	2.50	0.15	1.00+/-0.15	19.50/21.50	19.50	0.40	1.00+/-0.15
3.00/5.00	3.00	0.15	1.00+/-0.15	20.00/22.00	20.00	0.40	1.00+/-0.15
3.50/5.50	3.50	0.15	1.00+/-0.15	21.00/23.00	21.00	0.50	1.00+/-0.15
4.00/6.00	4.00	0.15	1.00+/-0.15	22.00/24.00	22.00	0.50	1.00+/-0.15
4.50/6.50	4.50	0.20	1.00+/-0.15	22.50/24.50	22.50	0.50	1.00+/-0.15
5.00/7.00	5.00	0.20	1.00+/-0.15	23.00/25.00	23.00	0.50	1.00+/-0.15
5.50/7.50	5.50	0.20	1.00+/-0.15	23.50/25.50	23.50	0.50	1.00+/-0.15
6.00/8.00	6.00	0.20	1.00+/-0.15	25.00/27.00	25.00	0.50	1.00+/-0.15
6.50/8.50	6.50	0.20	1.00+/-0.15	26.00/28.00	26.00	0.50	1.00+/-0.15
7.00/9.00	7.00	0.20	1.00+/-0.15	27.00/29.00	27.00	0.50	1.00+/-0.15
7.50/9.50	7.50	0.20	1.00+/-0.15	28.00/30.00	28.00	0.50	1.00+/-0.15
8.00/10.00	8.00	0.20	1.00+/-0.15	29.00/31.00	29.00	0.50	1.00+/-0.15
8.50/10.50	8.50	0.30	1.00+/-0.15	30.00/32.00	30.00	0.60	1.00+/-0.15
9.00/11.00	9.00	0.30	1.00+/-0.15	32.00/34.00	32.00	0.60	1.00+/-0.15
9.50/11.50	9.50	0.30	1.00+/-0.15	37.00/39.00	37.00	0.60	1.00+/-0.15
10.00/12.00	10.00	0.30	1.00+/-0.15	38.00/40.00	38.00	0.60	1.00+/-0.15
10.50/12.50	10.50	0.30	1.00+/-0.15	40.00/42.00	40.00	0.75	1.00+/-0.15
11.00/13.00	11.00	0.30	1.00+/-0.15	42.00/44.00	42.00	0.75	1.00+/-0.15
12.00/14.00	12.00	0.30	1.00+/-0.15	43.00/45.00	43.00	0.75	1.00+/-0.15
13.00/15.00	13.00	0.30	1.00+/-0.15	45.00/47.00	45.00	0.75	1.00+/-0.15
14.00/16.00	14.00	0.30	1.00+/-0.15	45.50/47.50	45.50	0.75	1.00+/-0.15
15.00/17.00	15.00	0.40	1.00+/-0.15	48.00/50.00	48.00	0.75	1.00+/-0.15
16.00/18.00	16.00	0.40	1.00+/-0.15	50.00/52.00	50.00	0.75	1.00+/-0.15

On all cases of military or commercial specifications, latest revisions apply.

Supplied in natural unless otherwise specified. Custom Pantone colors or ATAG standard colors available on request.

HIGH-TECH MICRO-BORE TUBING AND SLEEVING

Extruded PTFE, FEP, PFA, ETFE Tubing

EXTRUDED METRIC TUBING - WALL THICKNESS 1,50 MM

Ordering Size (ID/OD)	I.D.	Tolerance ±	Wall Thickness	Ordering Size (ID/OD)	I.D.	Tolerance ±	Wall Thickness
1.50/4.50	1.50	0.10	1.50+/-0.20	19.00/22.00	19.00	0.40	1.50+/-0.20
2.00/5.00	2.00	0.15	1.50+/-0.20	20.00/23.00	20.00	0.50	1.50+/-0.20
3.00/6.00	3.00	0.15	1.50+/-0.20	21.00/24.00	21.00	0.50	1.50+/-0.20
5.00/8.00	5.00	0.20	1.50+/-0.20	22.00/25.00	22.00	0.50	1.50+/-0.20
6.00/9.00	6.00	0.20	1.50+/-0.20	25.00/28.00	25.00	0.50	1.50+/-0.20
10.00/13.00	10.00	0.30	1.50+/-0.20	28.00/31.00	28.00	0.50	1.50+/-0.20
12.00/15.00	12.00	0.30	1.50+/-0.20	29.00/32.00	29.00	0.50	1.50+/-0.20
13.00/16.00	13.00	0.30	1.50+/-0.20	30.00/33.00	30.00	0.60	1.50+/-0.20
14.00/17.00	14.00	0.30	1.50+/-0.20	40.00/43.00	40.00	0.75	1.50+/-0.20
16.00/19.00	16.00	0.40	1.50+/-0.20	49.00/52.00	49.00	0.75	1.50+/-0.20
18.00/21.00	18.00	0.40	1.50+/-0.20				

EXTRUDED METRIC TUBING - WALL THICKNESS 2,00 MM

Ordering Size (ID/OD)	I.D.	Tolerance ±	Wall Thickness	Ordering Size (ID/OD)	I.D.	Tolerance ±	Wall Thickness
2.00/6.00	2.00	0.10	2.00+/-0.20	20.00/24.00	20.00	0.50	2.00+/-0.20
4.00/8.00	4.00	0.15	2.00+/-0.20	25.00/29.00	25.00	0.50	2.00+/-0.20
6.00/10.00	6.00	0.20	2.00+/-0.20	28.00/32.00	28.00	0.50	2.00+/-0.20
8.00/12.00	8.00	0.20	2.00+/-0.20	28.50/32.50	28.50	0.50	2.00+/-0.20
10.00/14.00	10.00	0.30	2.00+/-0.20	32.00/36.00	32.00	0.60	2.00+/-0.20
12.00/16.00	12.00	0.30	2.00+/-0.20	36.00/40.00	36.00	0.60	2.00+/-0.20
14.00/18.00	14.00	0.40	2.00+/-0.20	40.00/44.00	40.00	0.75	2.00+/-0.20
16.00/20.00	16.00	0.40	2.00+/-0.20	46.00/50.00	46.00	0.75	2.00+/-0.20

On all cases of military or commercial specifications, latest revisions apply.
Supplied in natural unless otherwise specified. Custom Pantone colors or ATAG standard colors available on request.

HIGH-TECH MICRO-BORE TUBING AND SLEEVING

PTFE Convoluted Tubing

STANDARD CONVOLUTED									
Part Number	Military Spec.	Identifier	I.D. Max.	I.D. min.	O.D. Max.	Wall Thickness Max.	Conv/Inch +/-1"	Weight LBS/CFT Max.	Bend Radius min.
CT-TS-012	AMS-T-81914/1	**01	0.188	0.181	0.32	0.023	8	2.0	0.500
CT-TS-018	AMS-T-81914/1	**02	0.281	0.273	0.414	0.027	7 1/2	2.9	0.750
CT-TS-020	AMS-T-81914/1	**03	0.312	0.303	0.45	0.027	7 1/2	3.6	0.875
CT-TS-024	AMS-T-81914/1	**04	0.375	0.364	0.53	0.029	7	4.2	1.000
CT-TS-028	AMS-T-81914/1	**05	0.437	0.425	0.59	0.029	7	4.9	1.250
CT-TS-032	AMS-T-81914/1	**06	0.500	0.485	0.66	0.029	7	5.2	1.500
CT-TS-040	AMS-T-81914/1	**07	0.625	0.608	0.78	0.035	7	6.9	1.750
CT-TS-048	AMS-T-81914/1	**08	0.750	0.730	0.975	0.035	6	10.4	1.875
CT-TS-056	AMS-T-81914/1	**09	0.875	0.850	1.10	0.035	6	11.3	2.250
CT-TS-064	AMS-T-81914/1	**10	1.000	0.975	1.26	0.035	4 1/2	12.6	2.500
CT-TS-072	AMS-T-81914/1	**11	1.125	1.105	1.39	0.035	4 1/2	13.8	2.750
CT-TS-080	AMS-T-81914/1	**12	1.250	1.210	1.539	0.035	4	15.5	3.000
CT-TS-096	AMS-T-81914/1	**13	1.500	1.440	1.85	0.040	4	21.7	3.750
CT-TS-079	AMS-T-81914/1	**14	1.750	1.690	2.10	0.045	4	25.3	4.250

The table above details ATAG and AMS-Spec. numbers and dimensions for our standard PTFE convoluted tubing. Custom sizes and configurations are also available.

EXTRA FLEXIBLE CONVOLUTED									
Part Number	Military Spec.	Identifier	I.D. Max.	I.D. min.	O.D. Max.	Wall Thickness Max.	Conv/Inch +/-1"	Weight LBS/CFT Max.	Bend Radius min.
CT-TE-012	AMS-T-81914/2	**01	0.188	0.181	0.32	0.023	10	2.2	0.313
CT-TE-018	AMS-T-81914/2	**02	0.281	0.273	0.414	0.026	9	3.8	0.438
CT-TE-020	AMS-T-81914/2	**03	0.312	0.306	0.450	0.027	9	4.8	0.438
CT-TE-024	AMS-T-81914/2	**04	0.375	0.364	0.530	0.029	9	5.6	0.500
CT-TE-028	AMS-T-81914/2	**05	0.437	0.427	0.590	0.029	9	6.5	0.500
CT-TE-032	AMS-T-81914/2	**06	0.500	0.485	0.660	0.029	9	6.9	0.750
CT-TE-040	AMS-T-81914/2	**07	0.625	0.608	0.780	0.029	9	9.2	0.750
CT-TE-048	AMS-T-81914/2	**08	0.750	0.730	0.975	0.035	8	13.8	0.938
CT-TE-056	AMS-T-81914/2	**09	0.875	0.860	1.100	0.035	8	15	0.938
CT-TE-064	AMS-T-81914/2	**10	1.000	0.975	1.260	0.035	7	16.8	1.125
CT-TE-072	AMS-T-81914/2	**11	1.125	1.105	1.390	0.035	6	17.5	1.125
CT-TE-080	AMS-T-81914/2	**12	1.250	1.210	1.539	0.035	6	19.6	1.250
CT-TE-096	AMS-T-81914/2	**13	1.500	1.450	1.810	0.038	6	26	2.000

The table above details ATAG and AMS-Spec. numbers and dimensions for our extra-flex PTFE convoluted tubing. Custom sizes and configurations are also available. Material and Dimensions comply with AMS-T-81914. Annual testing data provided. Lot to lot testing available upon request.

HIGH-TECH MICRO-BORE TUBING AND SLEEVING

FEP Convoluted Tubing

STANDARD CONVOLUTED									
Part Number	Military Spec.	Identifier	I.D. Max.	I.D. min.	O.D. Max.	Wall Thickness Max.	Conv/Inch +/-1"	Weight LBS/CFT Max.	Bend Radius min.
CT-FS-012	AMS-T-81914/3	**01	.187	.181	.320	.018	8	1.5	.500
CT-FS-018	AMS-T-81914/3	**02	.281	.273	.414	.018	8	1.7	.750
CT-FS-020	AMS-T-81914/3	**03	.312	.306	.450	.018	8	1.9	.750
CT-FS-024	AMS-T-81914/3	**04	.375	.364	.510	.018	8	2.2	.875
CT-FS-028	AMS-T-81914/3	**05	.437	.427	.571	.018	8	3.1	.875
CT-FS-032	AMS-T-81914/3	**06	.500	.485	.650	.023	7	4.0	1.250
CT-FS-040	AMS-T-81914/3	**07	.625	.608	.770	.023	7	4.8	1.500
CT-FS-048	AMS-T-81914/3	**08	.750	.730	.930	.023	6	6.1	1.750
CT-FS-056	AMS-T-81914/3	**09	.875	.860	1.073	.023	5	7.0	2.000
CT-FS-064	AMS-T-81914/3	**10	1.000	.975	1.226	.023	5	8.5	2.370
CT-FS-072	AMS-T-81914/3	**11	1.125	1.105	1.390	.023	5	9.3	2.370
CT-FS-080	AMS-T-81914/3	**12	1.250	1.210	1.539	.023	4	10.9	2.750
CT-FS-096	AMS-T-81914/3	**13	1.500	1.437	1.832	.023	4	12.6	3.380

The table above details ATAG and AMS-Spec. numbers and dimensions for our standard FEP convoluted tubing. Custom sizes and configurations are also available.

EXTRA FLEXIBLE CONVOLUTED									
Part Number	Military Spec.	Identifier	I.D. Max.	I.D. min.	O.D. Max.	Wall Thickness Max.	Conv/Inch +/-1"	Weight LBS/CFT Max.	Bend Radius min.
CT-FE-012	AMS-T-81914/4	**01	.188	.181	.320	.018	10	1.7	.31
CT-FE-018	AMS-T-81914/4	**02	.281	.273	.414	.018	10	2.0	.41
CT-FE-020	AMS-T-81914/4	**03	.312	.306	.450	.018	10	2.1	.41
CT-FE-024	AMS-T-81914/4	**04	.375	.359	.510	.018	10	2.5	.50
CT-FE-028	AMS-T-81914/4	**05	.437	.427	.571	.018	10	3.9	.50
CT-FE-032	AMS-T-81914/4	**06	.500	.480	.650	.023	9	4.6	.75
CT-FE-040	AMS-T-81914/4	**07	.625	.603	.770	.023	9	5.5	.75
CT-FE-048	AMS-T-81914/4	**08	.750	.725	.930	.023	8	6.9	.93
CT-FE-056	AMS-T-81914/4	**09	.875	.860	1.073	.023	7	8.9	1.25
CT-FE-064	AMS-T-81914/4	**10	1.000	.970	1.226	.023	7	9.5	1.25
CT-FE-072	AMS-T-81914/4	**11	1.125	1.105	1.390	.023	7	10.5	1.43
CT-FE-080	AMS-T-81914/4	**12	1.250	1.205	1.539	.023	6.5	11.2	1.43
CT-FE-096	AMS-T-81914/4	**13	1.500	1.437	1.832	.023	5.5	12.0	1.75

The table above details ATAG and AMS-Spec. numbers and dimensions for our Extra Flexible FEP convoluted tubing. Custom sizes and configurations are also available. Specs shown are for only Class 1 tubing. Material and Dimensions comply with AMS-T-81914. Annual testing data provided. Lot to lot testing available upon request.

HIGH-TECH MICRO-BORE TUBING AND SLEEVING

ETFE Convoluted Tubing

STANDARD CONVOLUTED									
Part Number	Military Spec.	Identifier	I.D. Max.	I.D. min.	O.D. Max.	Wall Thickness Max.	Conv/Inch +/-1"	Weight LBS/CFT Max.	Bend Radius min.
CT-ES-012	AMS-T-81914/6	**01	.187	.181	.320	.018	8	1.2	.500
CT-ES-018	AMS-T-81914/6	**02	.281	.273	.414	.018	8	1.4	.750
CT-ES-020	AMS-T-81914/6	**03	.312	.306	.450	.018	8	1.5	.750
CT-ES-024	AMS-T-81914/6	**04	.375	.364	.510	.018	8	1.8	.875
CT-ES-028	AMS-T-81914/6	**05	.437	.427	.571	.018	8	2.5	.875
CT-ES-032	AMS-T-81914/6	**06	.500	.485	.650	.023	7	3.2	1.250
CT-ES-040	AMS-T-81914/6	**07	.625	.608	.770	.023	7	3.9	1.500
CT-ES-048	AMS-T-81914/6	**08	.750	.730	.930	.023	6	4.9	1.750
CT-ES-056	AMS-T-81914/6	**09	.875	.860	1.073	.023	5	5.6	2.000
CT-ES-064	AMS-T-81914/6	**10	1.000	.975	1.226	.023	5	6.8	2.37
CT-ES-072	AMS-T-81914/6	**11	1.125	1.105	1.390	.023	5	7.5	2.37
CT-ES-080	AMS-T-81914/6	**12	1.250	1.210	1.539	.023	4	8.8	2.75
CT-ES-096	AMS-T-81914/6	**13	1.500	1.437	1.832	.023	4	10.2	3.38

The table above details ATAG and AMS-Spec. numbers and dimensions for our standard ETFE convoluted tubing. Custom sizes and configurations are also available.

EXTRA FLEXIBLE CONVOLUTED									
Part Number	Military Spec.	Identifier	I.D. Max.	I.D. min.	O.D. Max.	Wall Thickness Max.	Conv/Inch +/-1"	Weight LBS/CFT Max.	Bend Radius min.
CT-EE-012	AMS-T-81914/5	**01	.188	.181	.320	.018	10	1.4	.31
CT-EE-018	AMS-T-81914/5	**02	.281	.273	.414	.018	10	1.6	.41
CT-EE-020	AMS-T-81914/5	**03	.312	.306	.450	.018	10	1.7	.41
CT-EE-024	AMS-T-81914/5	**04	.375	.359	.510	.018	10	2.0	.50
CT-EE-028	AMS-T-81914/5	**05	.437	.427	.571	.018	10	3.1	.50
CT-EE-032	AMS-T-81914/5	**06	.500	.480	.650	.023	9	3.7	.75
CT-EE-040	AMS-T-81914/5	**07	.625	.603	.770	.023	9	4.4	.75
CT-EE-048	AMS-T-81914/5	**08	.750	.725	.930	.023	8	5.6	.93
CT-EE-056	AMS-T-81914/5	**09	.875	.860	1.073	.023	7	7.1	1.25
CT-EE-064	AMS-T-81914/5	**10	1.000	.970	1.226	.023	7	7.6	1.25
CT-EE-072	AMS-T-81914/5	**11	1.125	1.105	1.390	.023	7	8.4	1.43
CT-EE-080	AMS-T-81914/5	**12	1.250	1.205	1.539	.023	6	9.0	1.43
CT-EE-096	AMS-T-81914/5	**13	1.500	1.437	1.832	.023	5	9.6	1.75

The table above details ATAG and AMS-Spec. numbers and dimensions for our Extra Flexible ETFE convoluted tubing. Custom sizes and configurations are also available. Specs shown are for only Class 1 tubing. Material and Dimensions comply with AMS-T-81914. Annual testing data provided. Lot to lot testing available upon request.

HIGH-TECH MICRO-BORE TUBING AND SLEEVING

Heat Shrink Fluoropolymer Tubing

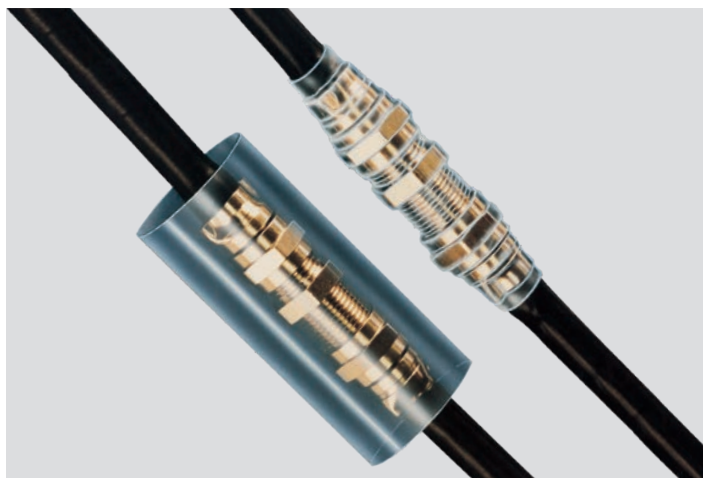

ATAG heat shrink tubing offers a unique combination of properties in its tubing, including outstanding electrical characteristics; excellent chemical and solvent resistances; purity; lubricity and outstanding performance reliability.

ATAG has mastered the art of manufacturing fluoropolymer heat shrink tubing and can supply it with recovered walls as thin as .002".

Please contact a ATAG representative to learn more about customer sizes, packaging, lengths and colors.

Heat Shrink Application Tips

1. Always assure good ventilation in the immediate work area prior to beginning the heat shrinking process.
Caution: Fumes may cause nausea and dizziness.
2. The mandrel to be covered by the heat shrink must be able to withstand the required temperature for material recovery (see table at right)
3. The mandrel being covered may act as a heat sink (especially metal mandrels). Therefore, ATAG recommends preheating mandrels
4. Heat shrink should be allowed to recover a minimum of 20%. Highly restricted radial recovery tends to induce longitudinal change and increase the tendency for splitting
5. Ovens are the most reliable way to recover heat shrink products due to their ability to ensure even heating and reduce the risk of over heating the material which can lead to brittleness and cracking.

TOP VIEW OF A ROLL IN A LATHE

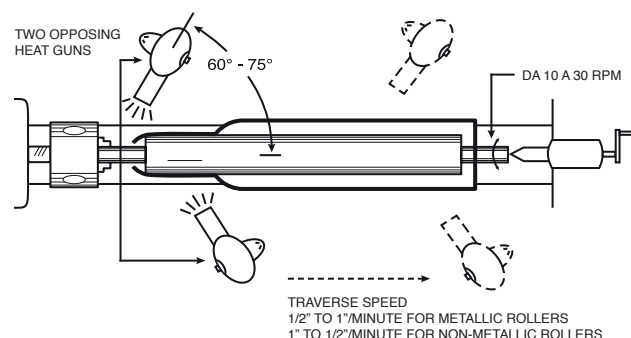

SAME PROCEDURE APPLIES FOR MANUAL ROTATION

If a heat gun will be used please refer to the picture above illustrating the proper application of heat to achieve the most uniform recovery

6. See Chart for recovery temperatures

HEAT SHRINK RECOVERY TEMPERATURE

Material	Recovery Temperature
PTFE	654 °F - 670 °F 346 °C - 354 °C
FEP (1" I.D. or less)	400 °F - 420 °F 204 °C - 216 °C
FEP (1" I.D. or greater)	420 °F - 440 °F 216 °C - 227 °C

The heat shrink temperatures listed in this catalog are general guidelines.

Actual shrink temperatures may be higher or lower depending on the design and dimensions of the heat shrink, application techniques and other factors.

Please contact an ATAG technical account manager for more information.

HIGH-TECH MICRO-BORE TUBING AND SLEEVING

PTFE Heat Shrink | 2 to 1 Shrink Ratio

Metric Dimensions (mm)

STANDARD WALL					THIN WALL					LIGHTWEIGHT WALL				
ordered ID AWG	Expanded I.D. Min.	Recovered I.D. Max	Recovered Wall Thickness		ordered ID AWG	Expanded I.D. Min.	Recovered I.D. Max	Recovered Wall Thickness		ordered ID AWG	Expanded I.D. Min.	Recovered I.D. Max	Recovered Wall Thickness	
			Nom.	Toll.				Nom.	Toll.				Nom.	Toll.
30 *	0.86	0.38	0.23	±.05	30	0.86	0.38	0.23	±.05	30 *	0.86	0.38	0.15	±.05
28 *	0.96	0.46	0.23	±.05	28	0.96	0.46	0.23	±.05	28 *	0.96	0.46	0.15	±.05
26 *	1.17	0.56	0.25	±.05	26	1.17	0.56	0.25	±.05	26 *	1.17	0.56	0.15	±.05
24	1.27	0.69	0.30	±.05	24	1.27	0.69	0.25	±.05	24	1.27	0.64	0.15	±.05
22	1.40	0.81	0.30	±.05	22	1.40	0.81	0.30	±.08	22	1.40	0.79	0.15	±.05
20	1.52	0.99	0.41	±.08	20	1.52	0.99	0.30	±.08	20	1.52	0.97	0.15	±.05
19	1.65	1.09	0.41	±.08	19	1.65	1.09	0.30	±.08	19	1.65	1.09	0.15	±.05
18	1.93	1.24	0.41	±.08	18	1.93	1.24	0.30	±.08	18	1.93	1.17	0.15	±.05
17	2.16	1.37	0.41	±.08	17	2.16	1.37	0.30	±.08	17	2.16	1.37	0.15	±.05
16	2.36	1.55	0.41	±.08	16	2.36	1.55	0.30	±.08	16	2.36	1.45	0.15	±.05
15	2.79	1.70	0.41	±.08	15	2.79	1.70	0.30	±.08	15	2.79	1.60	0.15	±.05
14	3.05	1.83	0.41	±.08	14	3.05	1.83	0.30	±.08	14	3.05	1.83	0.20	±.05
13	3.56	2.03	0.41	±.08	13	3.56	2.03	0.30	±.08	13	3.56	2.03	0.20	±.05
12	3.81	2.26	0.41	±.08	12	3.81	2.26	0.30	±.08	12	3.81	2.26	0.20	±.05
11	4.32	2.57	0.41	±.08	11	4.32	2.57	0.30	±.08	11	4.32	2.51	0.20	±.05
10	4.85	2.84	0.41	±.08	10	4.85	2.84	0.30	±.08	10	4.85	2.79	0.20	±.05
9	5.21	3.15	0.51	±.10	9	5.21	3.15	0.38	±.10	9	5.21	3.10	0.20	±.05
8	6.10	3.58	0.51	±.10	8	6.10	3.58	0.38	±.10	8	6.10	3.53	0.20	±.05
7	6.86	4.01	0.51	±.10	7	6.86	4.01	0.38	±.10	7	6.86	3.91	0.20	±.05
6	7.67	4.52	0.51	±.10	6	7.67	4.52	0.38	±.10	6	7.67	4.37	0.25	±.08
5	8.13	5.03	0.51	±.10	5	8.13	5.03	0.38	±.10	5	8.13	4.88	0.25	±.08
4	9.40	5.69	0.51	±.10	4	9.40	5.69	0.38	±.10	4	9.40	5.44	0.25	±.08
3	9.91	6.32	0.51	±.10	3	9.91	6.32	0.38	±.10	3	9.91	6.12	0.25	±.08
2	10.92	7.06	0.51	±.10	2	10.92	7.06	0.38	±.10	2	10.92	6.86	0.25	±.08
1	11.43	7.90	0.51	±.10	1	11.43	7.90	0.38	±.10	1	11.43	7.65	0.25	±.08
0	11.94	8.81	0.51	±.10	0	11.94	8.81	0.38	±.10	0	11.94	8.81	0.30	±.08

* AWG 30, 28, 26 SW e LW non sono conformi alla AMS-DTL-23053/12.

Metric Dimensions (mm)

STANDARD WALL - Class 2					THIN WALL - Class 3					INDUSTRIAL WALL - Class 1				
ordered ID Inches (in)	Expanded I.D. Min.	Recovered I.D. Max	Recovered Wall Thickness		ordered ID Inches (in)	Expanded I.D. Min.	Recovered I.D. Max	Recovered Wall Thickness		ordered ID Inches (in)	Expanded I.D. Min.	Recovered I.D. Max	Recovered Wall Thickness	
			Nom.	Toll.				Nom.	Toll.				Nom.	Toll.
1/8	5.46	3.30	0.51	±.10	1/8	5.46	3.30	0.38	±.08	1/8	4.22	3.30	0.76	±.13
1/4	10.41	6.60	0.51	±.10	1/4	10.41	6.60	0.38	±.08	3/16	6.35	4.90	0.76	±.13
5/16	11.94	8.36	0.51	±.10	5/16	11.94	8.36	0.38	±.08	1/4	8.46	6.53	0.76	±.13
3/8	14.22	10.13	0.64	±.15	3/8	14.22	10.13	0.38	±.08	5/16	10.54	8.13	0.76	±.13
7/16	16.64	11.73	0.64	±.15	7/16	16.64	11.73	0.46	±.10	3/8	12.65	9.73	0.76	±.13
1/2	19.05	13.31	0.64	±.15	1/2	19.05	13.31	0.46	±.10	7/16	14.73	11.38	0.76	±.15
5/8	23.62	16.64	0.76	±.15	5/8	23.62	16.64	0.51	±.10	1/2	16.92	12.95	0.76	±.15
3/4	28.58	19.96	0.89	±.20	3/4	28.58	19.96	0.64	±.13	9/16	19.00	14.53	0.76	±.15
7/8	33.27	23.14	0.89	±.20	7/8	33.27	23.14	0.76	±.15	5/8	21.08	16.18	0.76	±.15
1	38.10	26.31	0.89	±.20	1	38.10	26.31	0.76	±.15	11/16	23.24	17.78	0.81	±.15
										3/4	25.40	19.41	1.02	±.18
										7/8	29.72	22.63	1.14	±.18
										1	33.78	25.91	1.27	±.20

LIGHTWEIGHT WALL - Class 4				
ordered ID Inches (in)	Expanded I.D. Min.	Recovered I.D. Max	Recovered Wall Thickness	
			Nom.	Toll.
1/8	5.46	3.30	0.20	±.05
1/4	10.41	6.60	0.25	±.07
5/16	11.94	8.36	0.30	±.07

Conforms to AMS-DTL-23053/12.

Custom PANTONE colors or ATAG standard colors available on request.

Packaging: Standard 1,2 mt (4 ft) lengths, unless otherwise specified.

HIGH-TECH MICRO-BORE TUBING AND SLEEVING

PTFE Heat Shrink | 4 to 1 Shrink Ratio

Metric Dimensions (mm)

ordered ID Inches (in)	Expanded I.D.	RECOVERED - AFTER HEAT SHRINK		
		I.D. Max	Nom.	Wall Thickness Toll.
5/64	1.98	0.64	0.23	±.05
1/8	3.18	0.94	0.31	±.05
3/16	4.75	1.27	0.31	±.05
1/4	6.35	1.60	0.31	±.05
5/16	7.92	1.98	0.31	±.05
3/8	9.53	2.44	0.31	±.05
7/16	11.13	2.84	0.31	±.05
1/2	12.70	3.66	0.38	±.10
9/16	14.27	3.94	0.38	±.10
5/8	15.88	4.52	0.38	±.10
11/16	17.45	5.03	0.38	±.10
3/4	19.05	5.69	0.38	±.10
7/8	22.23	6.20	0.38	±.10
1	25.40	7.06	0.38	±.10
1-1/4	31.75	8.81	0.38	±.10
1-1/2	38.10	10.16	0.38	±.10
1-3/4	44.45	11.43	0.38	±.10
2	50.80	13.21	0.51	±.13
2-1/4	57.15	14.86	0.51	±.13
2-1/2	63.50	16.51	0.51	±.13
2-3/4	69.85	18.03	0.51	±.13
3	76.20	19.68	0.51	±.13
3-1/4	82.50	21.21	0.51	±.13
3-1/2	88.90	22.86	0.64	±.13
3-3/4	92.95	24.38	0.64	±.13
4	101.60	26.03	0.64	±.13

Conforms to AMS-DTL-23053/12, class 5.

Custom PANTONE colors or ATAG standard colors available on request.

HIGH-TECH MICRO-BORE TUBING AND SLEEVING

FEP Heat Shrink | 1.3 to 1 Shrink Ratio

Metric Dimensions (mm)

ordered ID AWG	As Supplied I.D. Minimum	RECOVERED - AFTER HEAT SHRINK			
		I.D. will shrink to at least	Minimum	Wall Thickness	
				Nominal	Maximum
24	0.79	0.69	0.15	0.20	0.25
22	0.91	0.81	0.15	0.20	0.25
20	1.14	0.99	0.15	0.20	0.25
18	1.52	1.25	0.15	0.20	0.25
16	1.91	1.55	0.18	0.23	0.28
14	2.34	1.83	0.18	0.23	0.28
12	2.92	2.26	0.18	0.23	0.28
10	3.58	2.90	0.18	0.25	0.33
9	4.01	3.15	0.18	0.25	0.33
8	4.57	3.63	0.18	0.25	0.33
7	5.00	4.01	0.18	0.28	0.38
6	5.72	4.57	0.18	0.28	0.38
5	6.30	5.03	0.18	0.28	0.38
4	7.37	5.74	0.18	0.28	0.38
3	7.87	6.32	0.18	0.28	0.38
2	9.27	7.11	0.20	0.30	0.41
1	10.16	7.90	0.20	0.30	0.41
0	11.18	8.86	0.20	0.30	0.41

Fractional INCH (in) Dimensions

ordered ID		As Supplied I.D. Minimum	RECOVERED - AFTER HEAT SHRINK			
INCHES (in)	mm		I.D. will shrink to at least	Minimum	Wall Thickness	
				Nominal	Maximum	
3/8"	9.53	12.70	9.73	0.28	0.38	0.48
7/16"	11.13	14.73	11.38	0.41	0.51	0.61
1/2"	12.70	16.92	12.95	0.41	0.51	0.61
5/8"	15.88	21.08	16.18	0.53	0.64	0.74
3/4"	19.05	25.40	19.41	0.66	0.76	0.86
7/8"	22.23	29.72	22.63	0.79	0.89	0.99
1"	25.40	33.78	25.91	0.79	0.89	0.99
1" 1/8	28.58	38.10	29.08	0.79	0.89	0.99
1" 1/4	31.75	42.32	32.26	0.79	0.89	0.99
1" 3/8	34.93	46.56	35.31	0.79	0.89	0.99
1" 1/2	38.10	50.80	39.88	0.79	0.89	0.99

Complies with AMS-DTL-23053/11, Class 1.

Supplied in natural unless otherwise specified.

Custom Pantone colors or ATAG standard colors available on request.

CUSTOM SPECIFICATIONS AND TOLERANCES QUOTED ON REQUEST

HIGH-TECH MICRO-BORE TUBING AND SLEEVING

FEP Heat Shrink | 1.6 to 1 Shrink Ratio

Metric Dimensions (mm)

ordered ID		As Supplied I.D. Minimum	I.D. will shrink to at least	Wall Thickness	
INCHES (in)	mm			Minimum	Maximum
3/32"	2.36	2.36	1.42	0.20	±0.08
1/8"	3.18	3.18	1.91	0.25	±0.08
3/16"	4.78	4.78	2.92	0.25	±0.08
1/4"	6.35	6.35	3.81	0.25	±0.08
3/8"	9.53	9.53	5.72	0.31	±0.08
1/2"	12.70	12.7	7.62	0.38	±0.10
3/4"	19.05	19.05	11.43	0.51	±0.10
1"	25.40	25.40	15.24	0.64	±0.13
1" 1/2	38.10	38.10	22.86	0.76	±0.13
2"	50.80	50.80	30.48	0.76	±0.13

Complies with AMS-DTL-23053/11, Class 2.

Supplied in natural unless otherwise specified.

Custom Pantone colors or ATAG standard colors available on request.

CUSTOM SPECIFICATIONS AND TOLERANCES QUOTED ON REQUEST

HIGH-TECH MICRO-BORE TUBING AND SLEEVING

FEP Heat Shrink | Roll Covers

ATAG Roll Covers extend the life and reliability of rollers and improve product quality.

A brief application of heat molds the cover snugly around the roll, forming a skintight, high-strength, impregnable jacket impervious to corrosive chemicals, solvents, acids, shock, abrasion, high temperatures, and moisture.

They eliminate sticky build-up problems.

With the use of a convenient heat source, such as a hot air gun, ATAG Roll Covers can be quickly and easily shrunk onto the rolls.

Cleaning can be done with a solvent or reagent.

For the printing, paper, textile, and food packaging industries, and others

- No sticking
- No picking
- Low maintenance
- Flexibility
- Excellent chemical resistance
- Handles delicate materials
- Saves labor costs
- Cuts cleaning time
- High temperature resistance

Fractional INCH (in) Dimensions

LARGE DIAMETER			SMALL DIAMETER		
ordered ID (in)	To Cover Roll Dia.		ordered ID (in)	To Cover Roll Dia.	
	Min.	Max		Min.	Max
1" 1/4	1.0	1.3	1/2"	.440	.550
1" 1/2	1.4	1.7	5/8"	.540	.700
2"	1.8	2.1	3/4"	.640	.800
2" 1/2	2.2	2.6	7/8 "	.760	.950
3"	2.7	3.1	1 "	.880	1.100
3" 1/2	3.2	3.6			
4"	3.5	4.2			
5"	4.4	5.2			
6"	5.4	6.2			
7"	6.4	7.2			

Metric Dimensions (mm)

LARGE DIAMETER			SMALL DIAMETER		
ordered ID (in)	To Cover Roll Dia.		ordered ID (in)	To Cover Roll Dia.	
	Min.	Max		Min.	Max
1" 1/4	25.40	33.02	1/2"	11.18	13.97
1" 1/2	35.56	43.18	5/8"	13.72	17.78
2"	45.92	53.34	3/4"	16.26	20.32
2" 1/2	55.88	66.04	7/8 "	19.30	24.13
3"	68.58	78.74	1 "	22.35	27.94
3" 1/2	81.28	91.44			
4"	88.90	106.68			
5"	111.76	132.08			
6"	137.16	157.48			
7"	162.56	182.88			

WALL THICKNESS: 0.020" (.508mm) Nominal.

COLOR: Natural. Custom colors available upon request.

Complete technical information provides helpful data to speed production and cut maintenance.

HIGH-TECH MICRO-BORE TUBING AND SLEEVING

High performance fibers: PEEK™

ATAG offers an arsenal of fibers designed to perform different and challenging applications.

Properties such as high tensile strength, optical clarity, high resistance to chemicals and temperatures characterize ATAG fiber. These light monofilaments also have superior characteristics of friction and wear resistance.

Our standard fiber offerings range from 0.003 "to 0.040" (0.0762 to 1.016 mm) and include PTFE, FEP, PFA, ETFE fibers as well as other fibers such as **PEEK™**, PVDF and ECTFE.

PEEK™ is a technologically advanced material with a unique combination of remarkable properties making it the most popular material among "advanced plastic materials". It is characterized by:

- High tensile strength
- Excellent sliding properties
- Excellent abrasion and wear resistance
- Lightweight material
- Excellent relationship between stiffness, resistance and resilience
- High dimensional stability at warm temperatures
- High continuous operating temperature

All **PEEK™** products described below are **on demand**.

PEEK™ Properties			
Properties	ASTM	Units	
Tensile Modulus	D638	KSI	621
Tensile Stress at Yield	D638	PSI	13,488
Glass Transition Temperature	D3418	°F/°C	289/143
Dielectric Strength V/mil	D149	V/mil	>500
Flammability Rating	UL 94		VO
Radiation Resistance		MRad	up to 1000
Coefficient of Friction	D1894		.35 - .50
Elongation	D638	%	50

These properties are based on natural resin and are for reference only. Actual performance may vary.

Extruded PEEK™ Tubing

Now available in Sub-Lite-Wall® configurations with wall thicknesses down to .002 on many sizes.

Tolerances +/- .001" (.025mm) are available in most sizes.

Call us for more details.

Metric Dimensions (mm)

Inner Diameter	Outer diameter	Pressure Rating *
.076	.508	2000 psi
.127	.508	2000 psi
.254	.508	2000 psi
.076	1.575	5000 psi
.127	1.575	5000 psi
.178	1.575	5000 psi
.254	1.575	5000 psi
.508	1.575	5000 psi
.762	1.575	5000 psi
1.016	1.575	5000 psi
1.397	1.575	5000 psi
1.575	3.175	5000 psi
2.032	3.175	3000 psi

* Suggested maximum safe operating pressure

HIGH-TECH MICRO-BORE TUBING AND SLEEVING

PEEK™ Heat Shrink | 1.4 to 1 Shrink Ratio

Heat-Shrinkable Tubing for Challenging Environments

Features

- Shrink temperature 626°F/330°C– 680°F/360°C
- Recovered wall range of 0.004" to 0.009"
- Custom sizes and lengths available upon request

Benefits

- Excellent abrasion resistance. Outstanding radiation resistance. High continuous operating temperature
- Extends life of the protected item. Adhesion to metals. Available in colors

Key Performance Attributes

- Forms a highly protective, shrink-to-fit shield against abrasion, extreme temperatures, high pressure, and dielectric interference.

Sample Applications

- Electrical component insulation. Protective jacketing provides excellent abrasion resistance
- Wire/cable insulation for medical devices. Wire splicing. Reusable medical devices

Note tecnica

- ATAG will assist in developing custom heat-shrink processes. Fillers available.
- Class VI approved materials available

PEEK™ Heat Shrink Tubing Properties

Properties	ASTM	Units	
Tensile Modulus	D638	KSI	1,309
Tensile Stress at Yield	D638	PSI	14,503
Glass Transition Temperature	D3418	°F/°C	321/161
Dielectric Strength	D149	V/mil	3570
Thermal Endurance	NEMA MW 1000	°F/°C	752/400
Crystallinity	D3814	%	40

This data is based on PEEKshrink® recovered on a .575" mandrel
Tubing performance and characteristics may change based on tubing size.

Metric Dimensions (mm)

TAG P7N	ordered ID AWG	As Supplied I.D. Minimum	Recovered I.D. Max	Recovered Dimensions After Shrinking Wall Thickness		
				Minimum	Nominal	Maximum
85322	17	0.038	0.027	0.005	0.007	0.009
85318	16	0.045	0.032	0.005	0.007	0.009
85184	15	0.055	0.039	0.005	0.007	0.009
85204	14	0.085	0.060	0.005	0.007	0.009
85197	13	0.092	0.065	0.005	0.007	0.009
85189	12	0.101	0.072	0.005	0.007	0.009
85313	11	0.112	0.080	0.005	0.007	0.009
85310	10	0.125	0.089	0.005	0.007	0.009
85298	9	0.137	0.098	0.005	0.007	0.009
85294	8	0.160	0.114	0.005	0.007	0.009
85146	7	0.174	0.124	0.005	0.007	0.009
85063	6	0.200	0.143	0.005	0.007	0.009
85213	5	0.221	0.158	0.005	0.007	0.009
85236	4	0.252	0.180	0.005	0.007	0.009
85243	3	0.277	0.198	0.005	0.007	0.009
85246	2	0.316	0.226	0.005	0.007	0.009
85255	1	0.349	0.249	0.005	0.007	0.009
85326	0	0.392	0.280	0.005	0.007	0.009

Standard length 1.2 mt (4 ft), unless otherwise indicated.

HIGH-TECH MICRO-BORE TUBING AND SLEEVING

PEEK™ Insulated Wire

Insulated Copper Wire for Challenging Environments

Regarded by many as the best performing thermoplastic, **PEEK™** has amazing strength, heat resistant properties, and is able to withstand intense pressure and caustic fluids.

ATAG **PEEK™** Insulated Wire results from the intermingling of **PEEK™** with copper wire. **PEEK™** Insulated Wire, also referred to as **PEEK™** Magnet Wire, has a high continuous operating temperature, excellent abrasion and chemical resistance, and dielectric strength. Material properties are maintained in long, continuous lengths without pinholes.

PEEK™ Insulated Wire is available in amorphous and crystalline forms in various sizes and can be spliced using **PEEK™** Heat Shrink.

Features

- 100% AC spark tested during extrusion
- Long, continuous lengths
- Crystalline **PEEK™** Insulated Wire available
- Round, square & rectangular profiles available

Benefits

- High continuous operating temperature
- Excellent abrasion resistance
- Dielectric strength
- Can be spliced using ATAG **PEEK™** Heat Shrink
- Annealed, solid, round bare copper wire according to ASTM B-3

Sample Applications

- Magnet wire/winding wire for motors
- Electrical insulation

PEEK™ Insulated Wire Properties

Properties	ASTM	Units	Nominal Test Value
Resistivity Testing	B3	Ω·lb/mile ²	859
Dielectric Breakdown	D149	kV RMS, at 60Hz	25
Relative Permittivity	D150		2.72
Dissipation Factor %	D150	%	0.14%
DC Resistance	D257	TΩ·in	2.72

Insulation thickness tested according to ASTM D374.
Performance and characteristics may change based on size.

AWG SIZE	Bare Wire Diameter (inches) Minimum	O.D. +/-0.015	OHMS Nominal Per/1000'	Total WT Per/1000'
6	0.1604	.1760	0.395	81.663
6.5	0.1514	.1675	0.444	72.864
7	0.1429	.1585	0.498	65.010
7.5	0.1348	.1505	0.559	58.022
8	0.1272	.1430	0.628	51.748
8.5	0.1201	.1358	0.705	46.206
9	0.1133	.1290	0.792	41.191
9.5	0.1069	.1225	0.889	36.797
10	0.1009	.1165	0.999	32.839
10.5	0.0952	.1108	1.121	29.345
11	0.0898	.1050	1.261	26.160
11.5	0.0847	.1000	1.415	23.370
12	0.0800	.0955	1.589	20.889
13	0.0713	.0867	2.001	16.703
14	0.0635	.0788	2.524	13.344

Standard Put Up: 1,500 ft Minimum Continuous Long Lengths Possible - Spool -- Longer continuous lengths available upon request

HIGH-TECH MICRO-BORE TUBING AND SLEEVING

Special Shapes *(All Special Shapes are custom ordered)*

MULTI-LUMEN

Unique extrusions providing multiple lumens or passages.

All MULTI-LUMENS are custom designed in different resins including but not limited to: PTFE, ePTFE, FEP, PFA, PEEK™ and more.

Design configurations are unlimited and are specific to your needs with all aspects kept confidentially to each customer.



A Multitude of MULTI-LUMEN Advantages

- Highly flexible
- Impervious to most corrosives
- Inert • Non-toxic
- Heat resistant to 500°F.
- Superior lubricity
- Biocompatible
- Reliable fluid transfer
- High dielectric strength

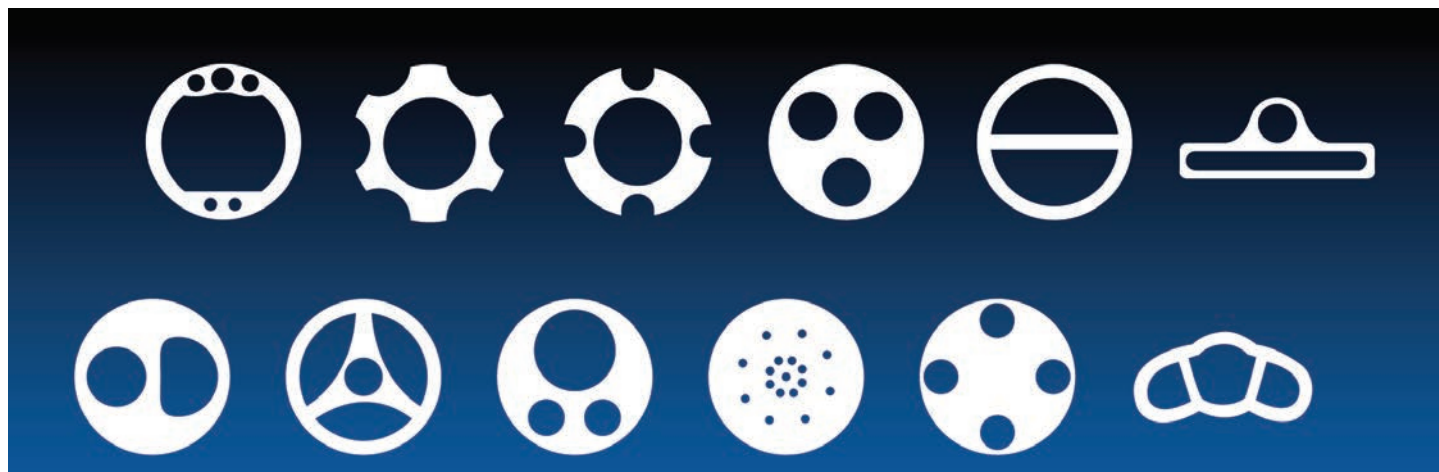

Lay-Flat Tubing

PET, FEP, PFA, PEEK™, PE and EVA

Dedicated to fulfilling the changes in the markets our customers serve, ATAG is pleased to offer lay-flat tubing. Lay-flat tubing was traditionally designed to meet the needs for ultrathin walls in the lighting and roller industries but now has applications in many medical and industrial markets. Lay-flat tubing made of high quality polymers offer strength, lubricity, chemical inertness and biocompatibility.

PET, FEP, PFA, PEEK™ e PE

Wall Sizes: .002" to .008"

ID Ranges: .250" to 5.000"

Lay Flat Widths: .400" to 7.75"

H/S: Expansion ratios up to 2:1 when applicable

Put Up: Spooled or cut to length

ATAG specializes in made-to-order sizes designed for your unique application.

Color: Natural. Custom colors available upon request.

Contact a Tech. Acct Manager for details.

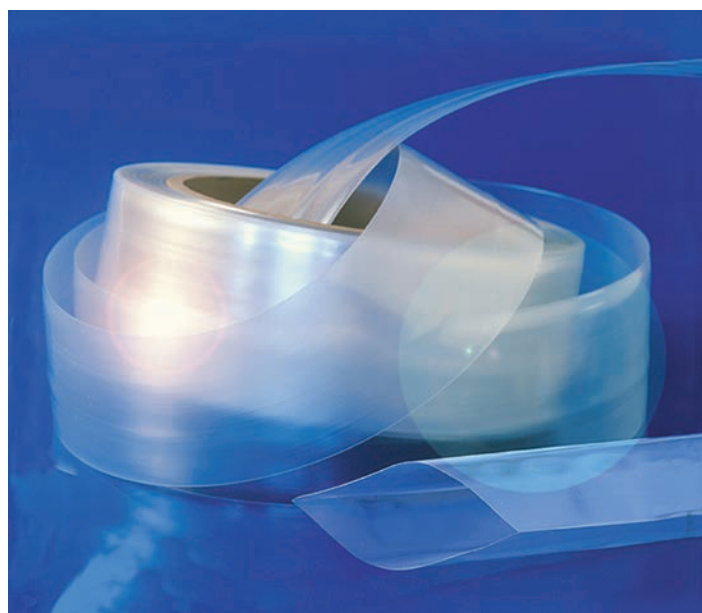

Connecting to the **download** section on our website and discover the whole **ATAG Universe**.

FLEXIBLE HOSES



EXPANSION JOINTS



INDUSTRIAL PLASTICS



EXTRUDED PROFILES, BUMPERS AND FOAM



RUBBER SHEETING

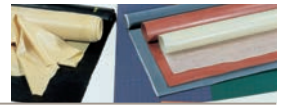

PIERCAN® SPECIAL GLOVES



RUBBER COATED ROLLERS



ANTI-VIBRATION



ELECTRICALLY HEATED HOSES



BIO-PHARMA-MEDICAL TUBING



FITTINGS



SPECIAL FLEXIBLE SOLUTIONS



HIGH TECH MICRO-BORE TUBING



INK ROLLER



EXPANDED RUBBER PRODUCTS



ATAG

SERVING INDUSTRY SINCE 1947



IT_20128 MILANO
ph. +39 02 255.22.51
mob. +39 329 68.78.260
ufftec@atag-europe.com

WWW.ATAG-EUROPE.COM