



INSTALLATION OF RUBBER EXPANSION JOINTS

INSTALLATION ADVICE

1. Before assembling the compensating joint make sure that both mating surfaces against the flanges have satisfactory contact: these must be flat, smooth, clean and without any burrs. Protruding extremities of the pipes, such as fluting or fins are not permitted as the sealing surface of the bellows could be slit or cut.

2. Be aware of the correct length of installation. The rubber expansion joints must be installed in a pre-stressed manner taking into account their permissible operating length so that they are almost stress-free during operating conditions. If the installation is too long then the locating bead of the rubber bellows can be pulled away from the retaining groove in the flange.

(Figure B, Detail 1)

3. When using standard flanges with through holes, make sure that the bolts do not interfere with the rubber body when the expansion joints is fully compressed. Ideally, position the bolt in such a way that the bolt head is facing towards the rubber body. If this is not possible then bolts with such a length must be used so that the minimal distance between the bolt head and the rubber body is not less than 15 mm. (Figure B, Detail 2)

4. If possible, install the compensation joint so that the production date is visible.

5. It is advised to use the class of resistance 8.8.

6. Bolts must be tightened gradually and alternatively in a uniform way following a diametrically opposite sequence as per the order indicated in Figure C.

7. Tightening is best done by securely holding the bolt head that acts on the inner face of the joint flange and turning the nut on the opposite flange. This avoids potentially damaging the rubber body with the spanner.

8. If a torque wrench is available, then tighten the bolts in 3 stages:

- Tighten the bolts uniformly by hand, paying attention that the flange surfaces are parallel.
- Tighten diametrically opposite bolts with a torque of 50 Nm following Figure C as previously described.
- To lock the bolts, apply the torque as indicated in the table of Figure C based on the installed joint.

9. If a torque wrench is not available, the bolts must be tightened until the external edge of the rubber bellows compresses slightly under the action of the metal faces of the flanges, leaving between the two a distance at least 1 millimetre.

(Figure B, Detail 3)

ATAG reserves the right to make changes without notice, by virtue of any quality improvements and/or product specifications - apr 20 rbd

Figure A

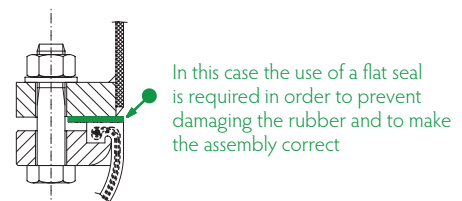
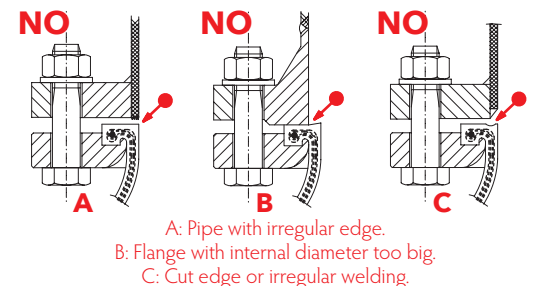
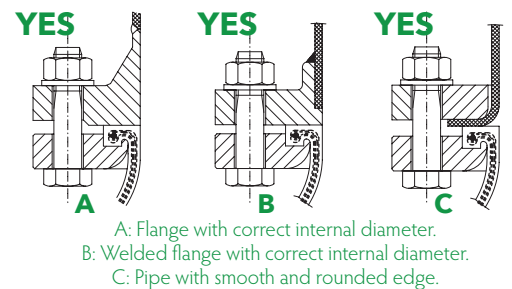

Figure B

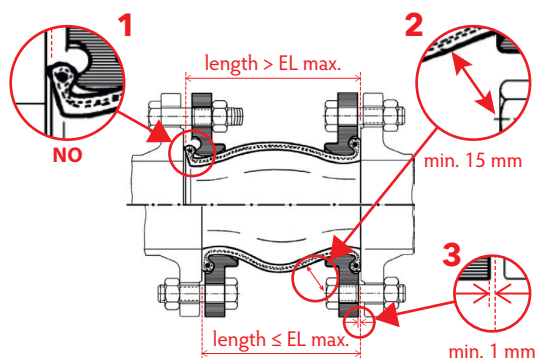

Figure C

TORQUE FOR TIGHTENING NUTS	
up to DN 80	→ max 80 Nm
up to DN 300	→ max 100 Nm
up to DN 500	→ max 130 Nm
DN 700	→ 250 Nm
DN 800	→ 300 Nm
DN 900	→ 310 Nm
DN 1000	→ 340 Nm

